









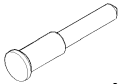

# NR.103

 <b>3.5x16</b> S02 <b>x63</b>	 D01 <b>x1</b>	 S01 <b>x34</b>	 P01 <b>x4</b>	 C01 <b>x24</b>	 <b>3.5x25</b> S03 <b>x4</b>
 B01 <b>x8</b>	 S21 <b>x8</b>	 M01 <b>x4</b>	 S11 <b>x8</b>	 A01 <b>x2</b>	 CL <b>x2</b>

II

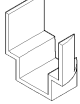
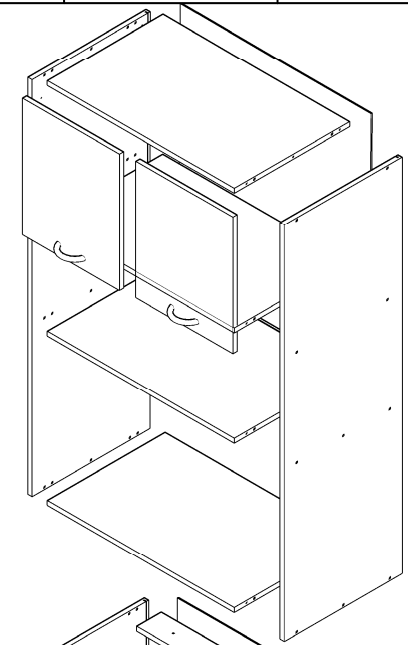

I

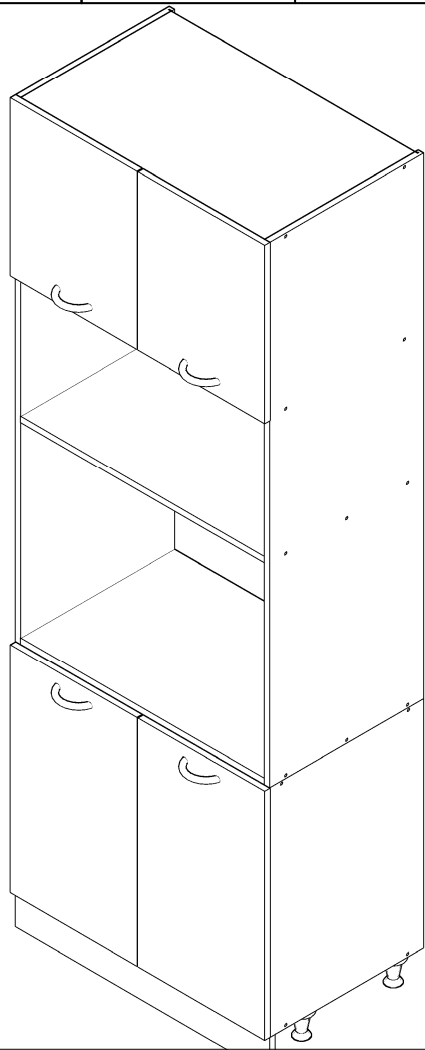
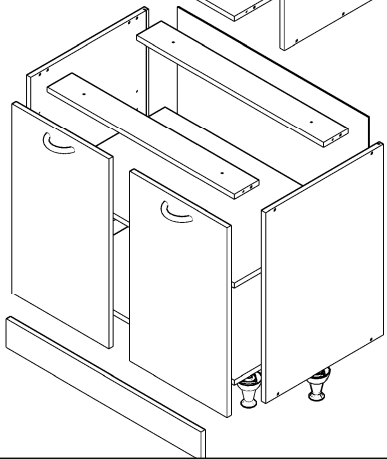

I.1

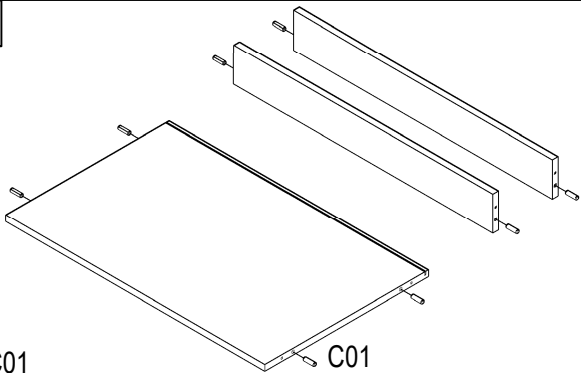

8x C01

C01

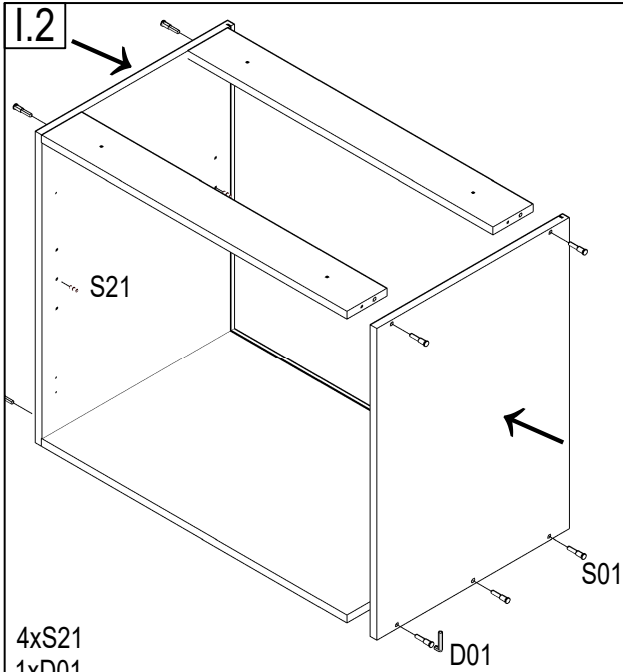

4xS21  
1xD01  
10xS01

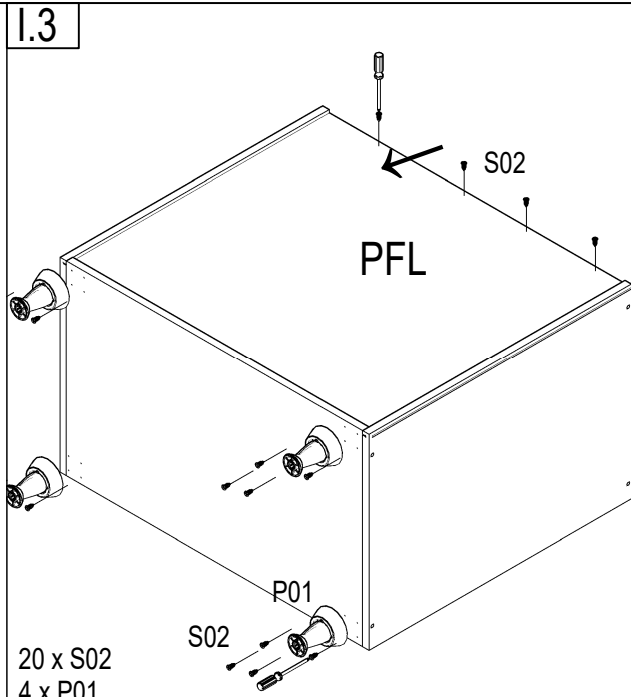

20 x S02  
4 x P01

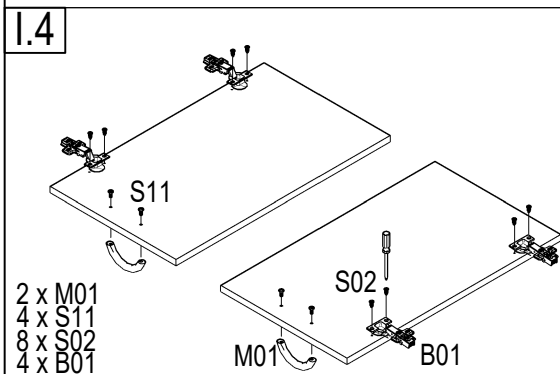

2 x M01  
4 x S11  
8 x S02  
4 x B01

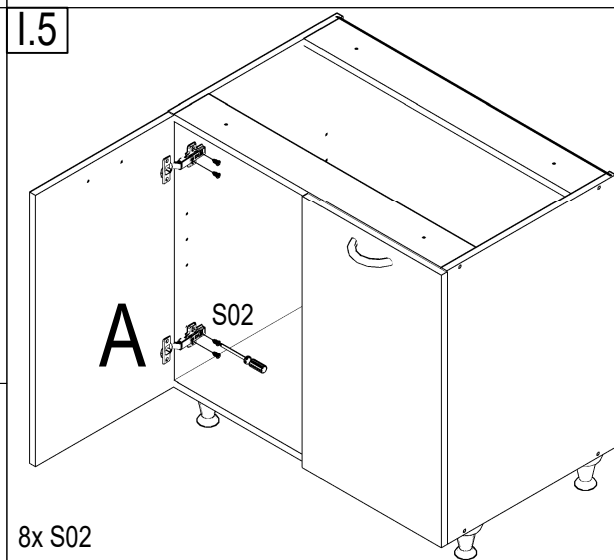

8x S02

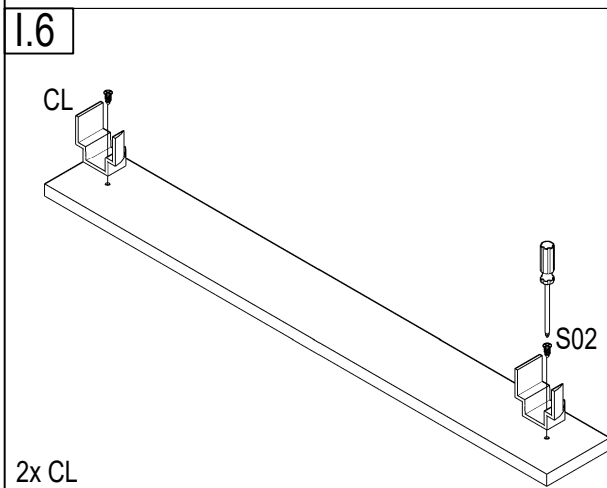

2x CL  
2x S02

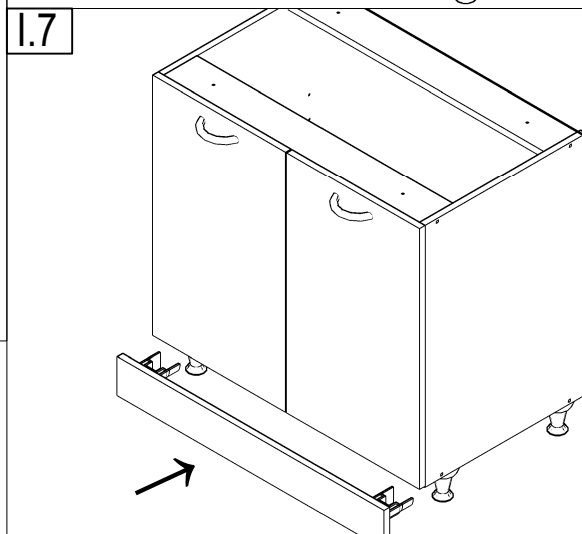

II.1

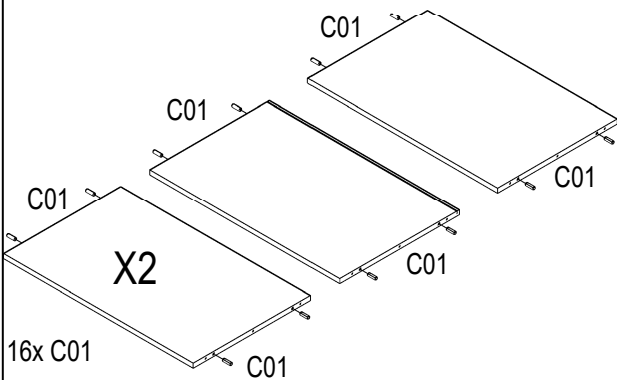

II.2

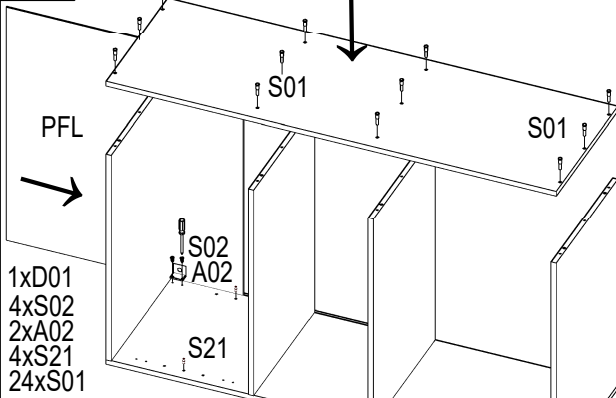

II.3

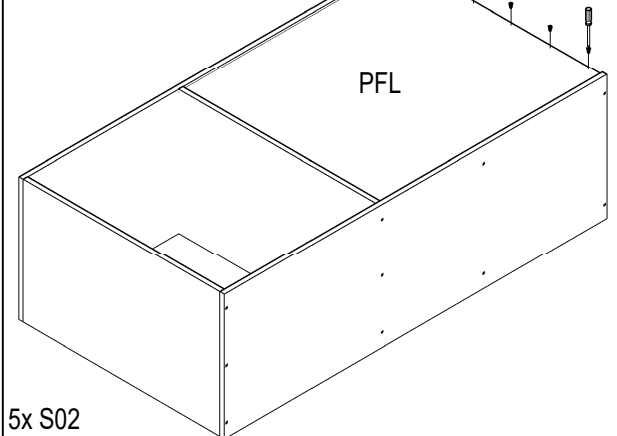

II.4

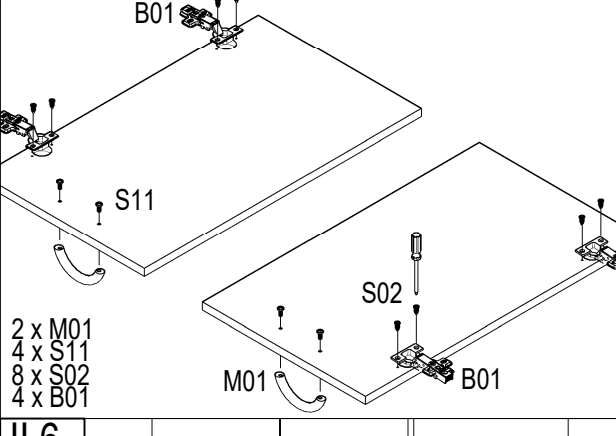

II.5

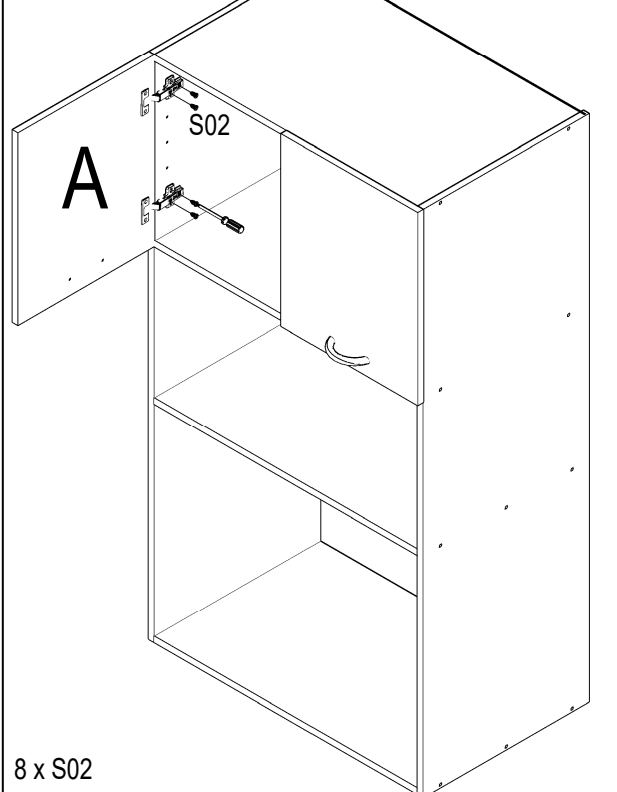

II.6

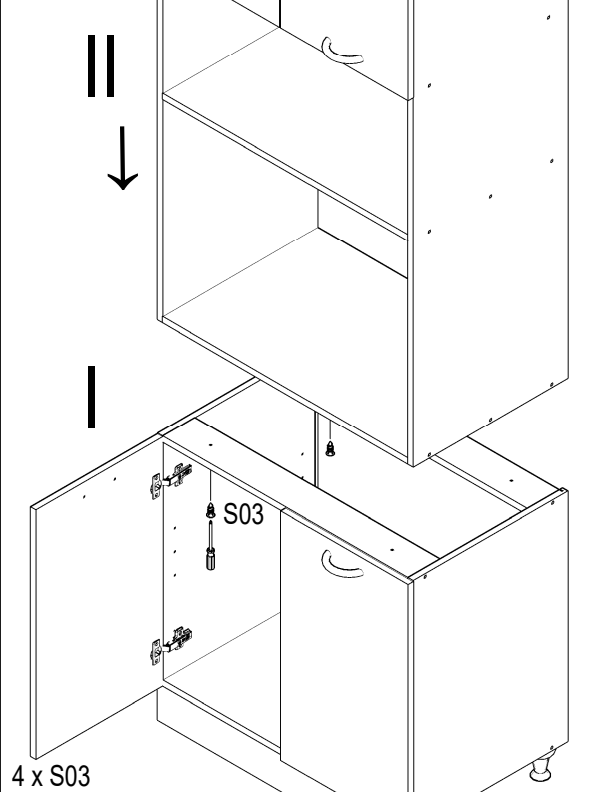

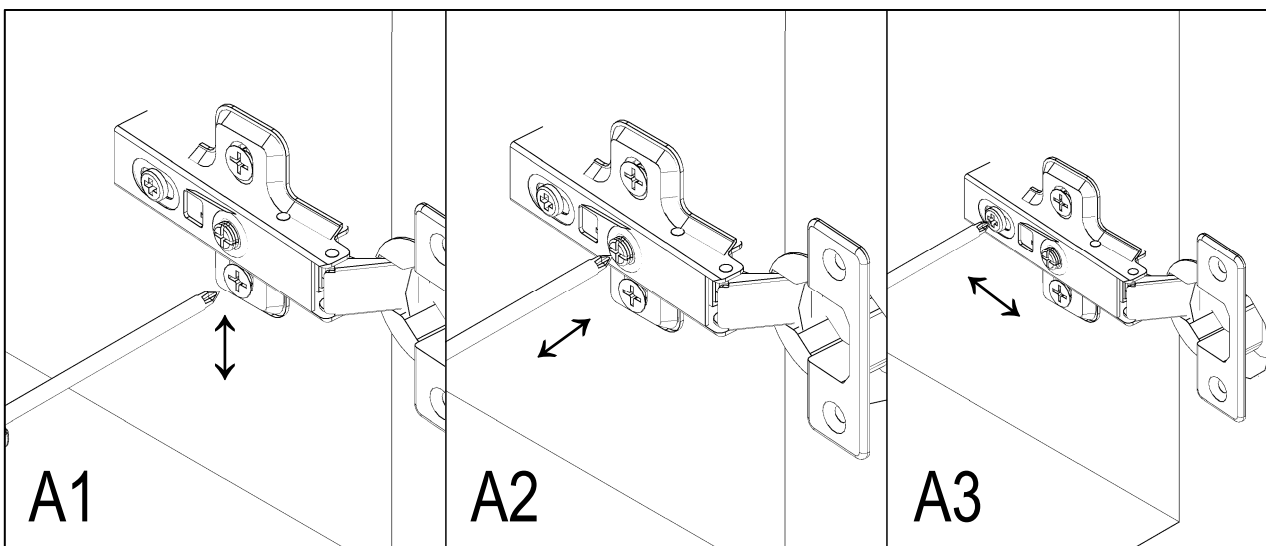

A1

A2

A3

HEIGHT ADJUSTEMENT    SIDE ADJUSTEMENT    DEPTH ADJUSTEMENT